



# Dental

Optimized Tools for CAD-CAM Machines



47-2 Cheongnong-ro Bupueong-gu, Incheon, South Korea

✉ oneden@oneden.kr

☎ +82 32 513 2344

☎ +82 32 724 4340

<https://www.oneden.kr>



# ONEDEN



The ONEDEN company was founded in 2022 and is located in Incheon, South Korea.

With sophisticated equipment as well as the latest manufacturing technologies, ONEDEN will provide a whole new family of cutting tools such as End Mills, Drills, and Burrs for the dental industry.

These state-of-the-art products are geared for the manufacturing of dental prostheses through CAD-CAM machines.

The tools will be specifically built under proprietary know-how for adequate geometry and edge prep to give the best performance for each machine and material (PMMA, Glass Ceramics, Zirconia, Cobalt Chrome, and Titanium).

In addition, ONEDEN is using newly developed coatings, and various grades of Carbide raw materials to match requirements.

Outstanding quality is the drive of ONEDEN.

A team of Dental Tool Application specialists is in place and committed to provide the best technical support in selecting the right product for the application.

***There is no doubt that ONEDEN will become a key player in supplying tooling for the Dental Industry.***



## Advantage of 3 flutes versus 2 Flutes in Zirconia.

The difference between Metals (Cobalt Chrome, Titanium), PMMA, and Zirconia is that in the Milling operations of Metals and PMMA, we are creating chips and in Zirconia we are creating powder.

If we are using the same feed on 3 flutes in Zirconia the advantage will be getting a smoother cut with less load and much better tool life.

If we run the same chip load, then the feed rate will be 33% faster.

## Coating

ONEDEN is producing tools using state-of-the-art manufacturing equipment together with the latest coating technologies. We provide PVD and CVD (Diamond) Coating.

We also use the most advanced technology in Electroplating while using diamond grit which offers an excellent binding to avoid micro-cracks and reduces the sensitivity to thermal impact.

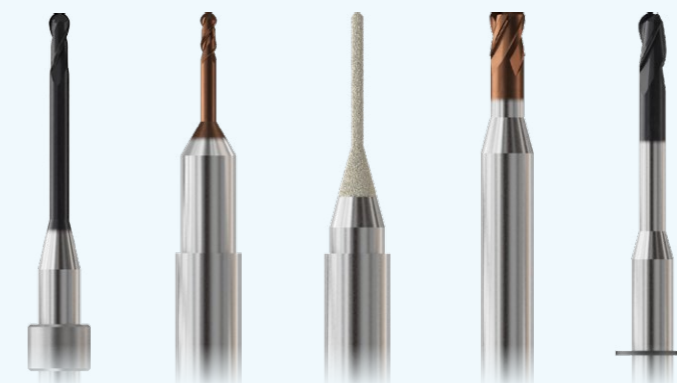

In PVD Coating we are using our TS Coating which has a specific advantage for Cobalt Chrome and Titanium materials.

For the Zirconia we are using Diamond coating, while for PMMA and Plastic, we are using DLC (Diamond Like Carbon).

For Glass Ceramics, we are using Electroplated Diamond.



## Designation (Item No.) structure

Shape / Coating / Machine					Specification					
Sortation	Flute	Form	Coating	Machine	Diameter (OD)	Effective Length (LBS)	Shank Diameter (SD)	Overall Length (OAL)	Corner R	Identical code classification
Item No.	<b>2</b>	<b>1</b>	<b>2</b>	<b>06</b>	<b>30</b>	<b>125</b>	<b>4</b>	<b>50</b>	<b>03</b>	<b>A</b>
Location	1	2	3	4	5	6	7	8	9	10

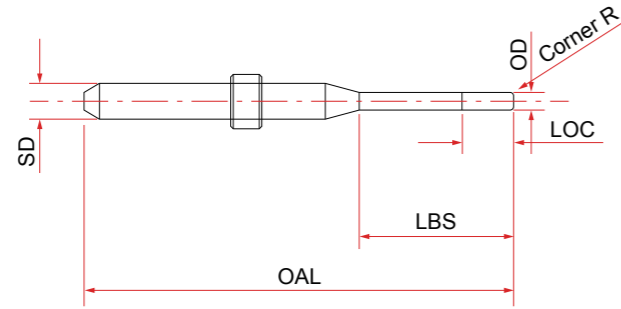

### 1. Flute

Example	Record
NO	0
1 Flute	1
2 Flute	2
3 Flute	3
4 Flute	4
5 Flute	5
6 Flute	6

### 2. Form

Example	Record
Ball	1
Flat	2
Toric	3
Drill	4
R Cutter	5
T-Cutter	6
Thread Mill	7
Reamer	8

### 3. Coating

Example	Record
Uncoated	0
EL-DIA	1
DIA	2
TS	3
DLC	4
S-DLC	5
TA	6
AV	7
AT	8

### 4. Machine

Example	Record
Amann	01
Arum	02
Ceracube	03
Charly	04
Dentium	05
DOF	06
Elben	07
Imes-Icore	08
Lezirth	09
Manix	10
NeoBiotech	11
Protech Innotion	12
Rnd	13
Roland	14
Sirona	15
Ugint	16
VHF	17
Wieland	18
YenaDent	19
ZIRKONZAHN	20
Z-match	22
CAMEleon	23
Dental plus	24
DATRON	25
Redon	26
AIDITE	30
CNC Dental	32
Osstem	33

### 5. Mill Diameter(OD)

Example	Record
0.6	06
1.0	10
1.5	15
2.0	20
2.5	25
3.0	30

### 6. Effective Length(LBS)

Example	Record
5.0	050
5.5	055
12.0	120
12.5	125
13.0	130
16.0	160

### 7. Shank Diameter(SD)

Example	Record
3	3
4	4
6	6

### 8. Overall Length(OAL)

Example	Record
35	35
38	38
40	40
45	45
50	50
55	55
57	57
60	60
63	63

### 9. Corner R

Example	Record
R0.3	03
R0.5	05
R1.0	10
R1.5	15
R2.0	20

### 10. Identical code classification

Example	Record
Identical code classification 1st	A
Identical code classification 2nd	B

## CONTENTS

MACHINE	Shank Diameter (mm)	MATERIAL	TOOL	Type	Flutes	Coating	Cutting Diameter (Ø)		PAGE
							MIN	MAX	
AIDITE AMW-520, AMD-500D/C Compatible	4	Zirconia (ZrO <sub>2</sub> )		Ball	2 & 3	DIA	0.6	2.0	7
	6	Glass Ceramics		Ball	N/A	EL-DIA	0.6	2.5	7
Amann Girrbach CERAMILL Series Compatible	3	Zirconia (ZrO <sub>2</sub> )		Ball	2	DIA	0.6	2.5	8
Arum Compatible	4	Glass Ceramics		Ball	N/A	EL-DIA	0.6	2.5	9
	6			Ball	N/A	EL-DIA	0.6	2.5	
	4	Zirconia (ZrO <sub>2</sub> )		Ball	2	DIA	0.6	2.0	10
	6			Ball	2	DIA	0.6	2.0	
	6	Cobalt Chrome / Titanium		Ball	2	TS	0.6	3.0	11
	CNC Dental Compatible	6			Ball	2	TS	1.0	3.0
6		Toric			4 & 5	TS	3.0	6.0	
6		Cobalt Chrome / Titanium		Ball	2	TS	1.0	2.0	13
6				Flat	2	TS	0.5	2.0	
6		Toric	2 & 4	TS	1.0	3.0			
6									
DATRON Compatible	6	Cobalt Chrome / Titanium		Ball	2	TS	1.0	3.0	14
DOF CRAFT-5X	4	Zirconia (ZrO <sub>2</sub> )		Ball	2	DIA	0.6	2.0	15
	4	PMMA		Ball	2	DLC	1.0	2.0	15
DOF Sharp2-5X	4	Cobalt Chrome / Titanium		Ball	3	TS	1.0	2.0	16
	3	Zirconia (ZrO <sub>2</sub> )		Ball	2	DIA	0.6	2.0	16
Imes-Icore Compatible Shank 6mm	6	Zirconia (ZrO <sub>2</sub> )		Ball	2 & 3	DIA	0.6	2.5	17
	6	PMMA / WAX / PEEK		Ball	1	Uncoated	1.0	2.5	17
	6	Cobalt Chrome / Titanium		Ball	2	TS	1.0	3.0	18
	6	Glass Ceramics		Ball	N/A	EL-DIA	0.6	2.5	18

MACHINE	Shank Diameter (mm)	MATERIAL	TOOL	Type	Flutes	Coating	Cutting Diameter (∅)		PAGE
							MIN	MAX	
Imes-Icore Compatible Shank 3mm	3	Zirconia (ZrO <sub>2</sub> )		Ball	2	DIA	0.6	2.5	19
	3	Glass Ceramics		Ball	N/A	EL-DIA	0.6	2.5	19
Redon Compatible	4	Cobalt Chrome / Titanium		Ball	2	TS	1.0	2.0	20
	4		Toric	5	TS	2.5	2.5		
	4	Toric	5	AV	2.5	2.5	21		
	4	Glass Ceramics		Ball	N/A	EL-DIA		0.6	2.5
Roland Compatible	4	Zirconia (ZrO <sub>2</sub> )		Ball	2 & 3	DIA	0.6	2.0	22
	4	PMMA		Ball	1	DLC	1.0	2.0	22
	4	Universal Material /WAX / PEEK		Ball	2	TA	0.3	2.0	23
	4		Flat	2	TA	1.5	4.0		
	4		Toric	3	TA	4.0	4.0		
	3	Glass Ceramics		Ball	N/A	EL-DIA	0.5	2.5	24
Sirona Compatible	3	Zirconia (ZrO <sub>2</sub> )		Ball	2 & 4	DIA	0.5	2.5	25
VHF Compatible (Dry Machining)	3	Zirconia (ZrO <sub>2</sub> )		Ball	2 & 3	DIA	0.6	2.0	26
	3		Flat	2	DIA	1.2	1.2		
	3	PMMA / WAX / PEEK		Ball	1	Uncoated	1.0	2.0	27
	3		Flat	1	Uncoated	2.5	2.5		
	3	Universal Material /WAX / PEEK		Ball	2	Uncoated	0.3	0.3	28
	3		Ball	2	TA	0.6	0.6		
	3	Glass Ceramics		Ball	N/A	EL-DIA	0.6	2.4	28
ZIRKONZAHN Compatible (Dry Machining)	6	Zirconia (ZrO <sub>2</sub> )		Ball	2	DIA	0.5	2.0	29
	3		Ball	2	DIA	0.5	2.0		

## AIDITE AMW-520, AMD-500D/C Compatible

### Zirconia (ZrO<sub>2</sub>)

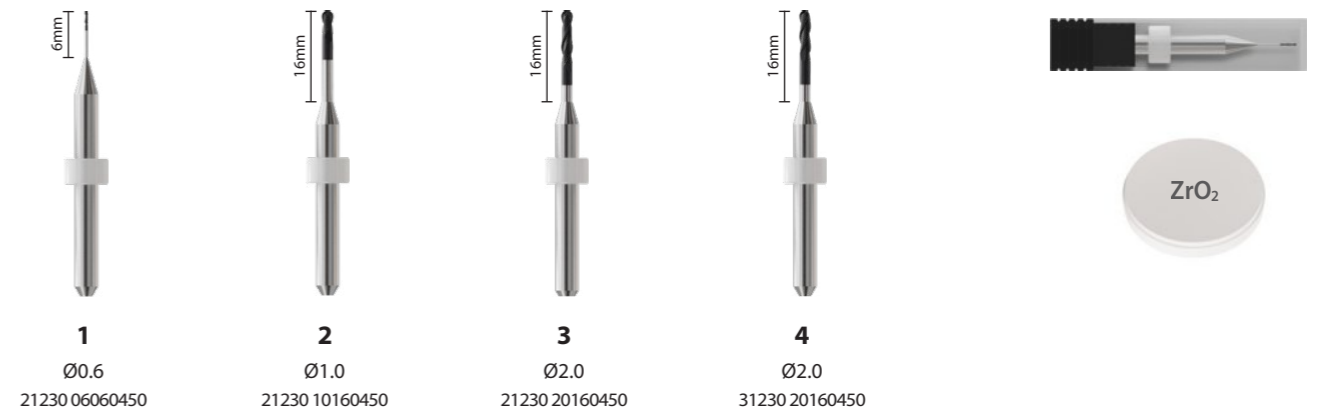

No.	EDP	Type	Coating	Flutes	OD [mm]	LOC [mm]	LBS [mm]	SD [mm]	OAL [mm]
1	21230 06060450	Ball	DIA	2	0.6	1	6	4	50
2	21230 10160450	Ball	DIA	2	1.0	2.5	16	4	50
3	21230 20160450	Ball	DIA	2	2.0	5.5	16	4	50
4	31230 20160450	Ball	DIA	3	2.0	5.5	16	4	50

### Glass Ceramics



No.	EDP	Type	Coating	Flutes	OD [mm]	LOC [mm]	LBS [mm]	SD [mm]	OAL [mm]
1	01130 06040650	Ball	EL-DIA	N/A	0.6	4	4	6	50
2	01130 10080650	Ball	EL-DIA	N/A	1.0	8	8	6	50
3	01130 25140650	Ball	EL-DIA	N/A	2.5	14	14	6	50

AIDITE  
Amann  
Arum  
CNC Dental  
DATRON  
DOF  
Imes-Icore  
Redon  
Roland  
Sirona  
VHF  
ZIRKONZAHN

## Amann Girrbach CERAMILL Series Compatible

### Zirconia (ZrO<sub>2</sub>)



No.	EDP	Type	Coating	Flutes	OD [mm]	LOC [mm]	LBS [mm]	SD [mm]	OAL [mm]
1	21201 06120347	Ball	DIA	2	0.6	2	12	3	47
2	21201 10160347	Ball	DIA	2	1.0	2.1	16	3	47
3	21201 25180347	Ball	DIA	2	2.5	4	18	3	47

## Arum Compatible - Wet Machining

### Glass Ceramics

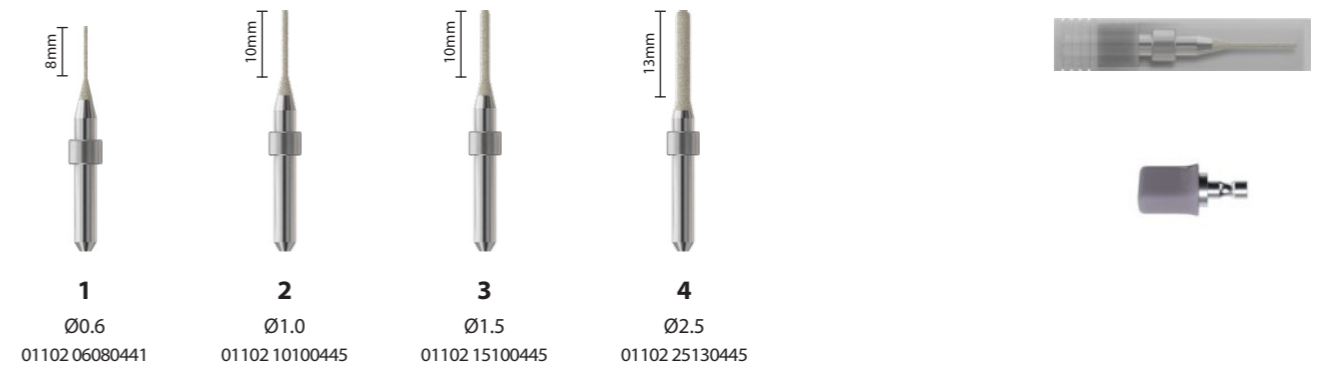

No.	EDP	Type	Coating	Flutes	OD [mm]	LOC [mm]	LBS [mm]	SD [mm]	OAL [mm]
1	01102 06080441	Ball	EL-DIA	N/A	0.6	8	8	4	41
2	01102 10100445	Ball	EL-DIA	N/A	1.0	10	10	4	45
3	01102 15100445	Ball	EL-DIA	N/A	1.5	10	10	4	45
4	01102 25130445	Ball	EL-DIA	N/A	2.5	13	13	4	45

### Glass Ceramics

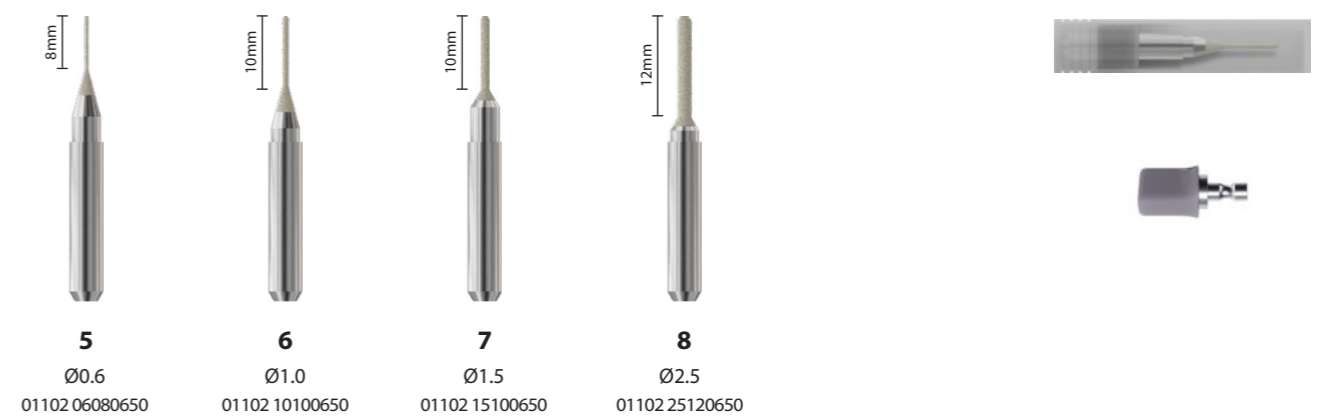

No.	EDP	Type	Coating	Flutes	OD [mm]	LOC [mm]	LBS [mm]	SD [mm]	OAL [mm]
5	01102 06080650	Ball	EL-DIA	N/A	0.6	8	8	6	50
6	01102 10100650	Ball	EL-DIA	N/A	1.0	10	10	6	50
7	01102 15100650	Ball	EL-DIA	N/A	1.5	10	10	6	50
8	01102 25120650	Ball	EL-DIA	N/A	2.5	12	12	6	50

## Arum Compatible - Dry Machining

### Zirconia (ZrO<sub>2</sub>)



No.	EDP	Type	Coating	Flutes	OD [mm]	LOC [mm]	LBS [mm]	SD [mm]	OAL [mm]
1	21202 06100445	Ball	DIA	2	0.6	1.5	10	4	45
2	21202 10160450	Ball	DIA	2	1.0	2	16	4	50
3	21202 20180450	Ball	DIA	2	2.0	6	18	4	50

### Zirconia (ZrO<sub>2</sub>)



No.	EDP	Type	Coating	Flutes	OD [mm]	LOC [mm]	LBS [mm]	SD [mm]	OAL [mm]
5	21202 06080650	Ball	DIA	2	0.6	1.6	8	6	50
6	21202 10140653	Ball	DIA	2	1.0	2	14	6	53
7	21202 20200655	Ball	DIA	2	2.0	6	20	6	55

## Arum Compatible

### Cobalt Chrome / Titanium

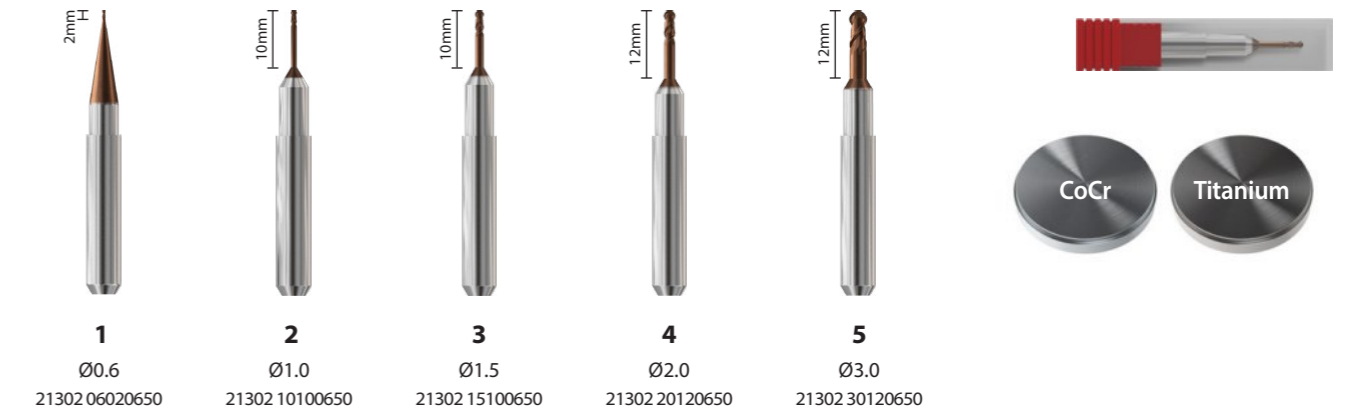

No.	EDP	Type	Coating	Flutes	OD [mm]	LOC [mm]	LBS [mm]	SD [mm]	OAL [mm]
1	21302 06020650	Ball	TS	2	0.6	1	2	6	50
2	21302 10100650	Ball	TS	2	1.0	2	10	6	50
3	21302 15100650	Ball	TS	2	1.5	3	10	6	50
4	21302 20120650	Ball	TS	2	2.0	4	12	6	50
5	21302 30120650	Ball	TS	2	3.0	4.5	12	6	50

## CNC Dental Compatible

### Cobalt Chrome / Titanium

Wet/Dry/MQL

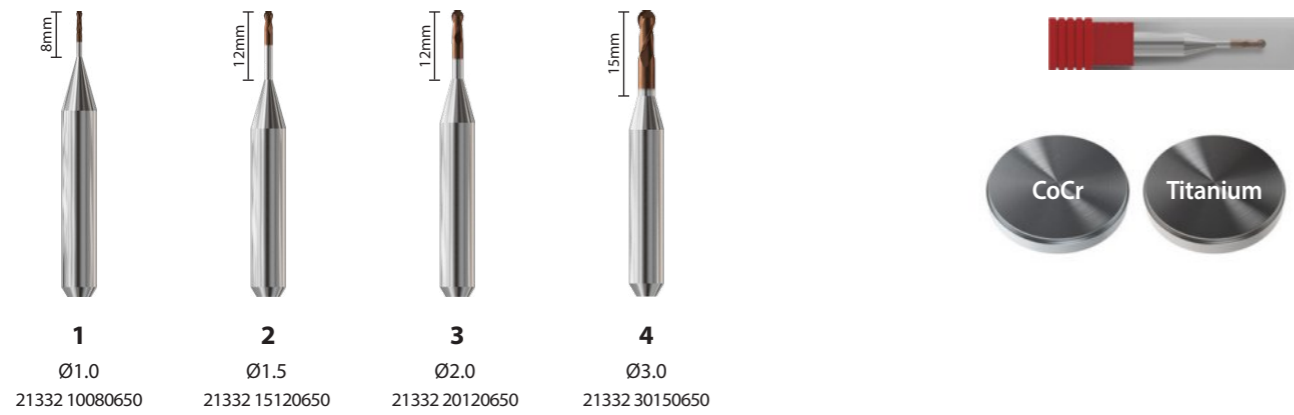

No.	EDP	Type	Coating	Flutes	OD [mm]	LOC [mm]	LBS [mm]	SD [mm]	OAL [mm]
1	21332 10080650	Ball	TS	2	1.0	3	8	6	50
2	21332 15120650	Ball	TS	2	1.5	3	12	6	50
3	21332 20120650	Ball	TS	2	2.0	3.5	12	6	50
4	21332 30150650	Ball	TS	2	3.0	5.5	15	6	50

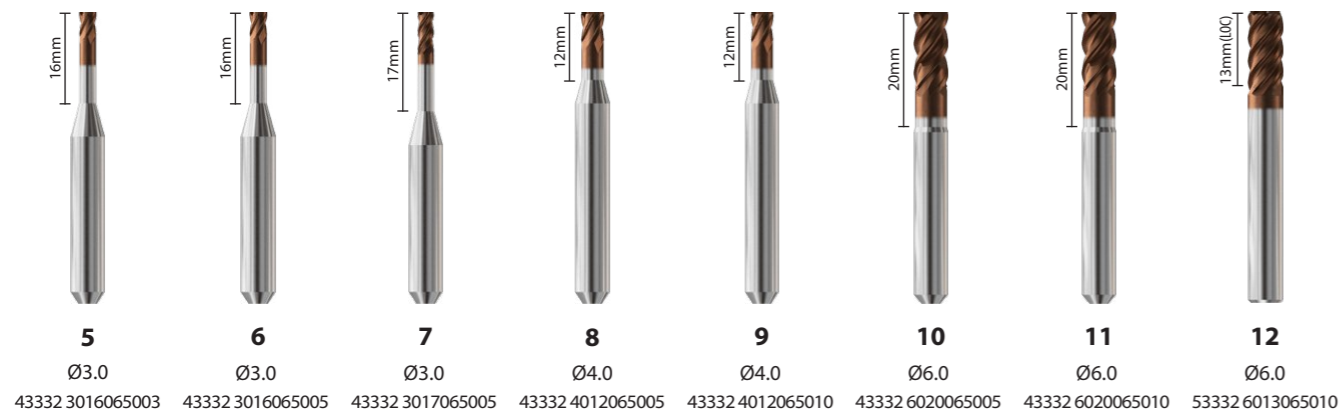

No.	EDP	Type	Coating	Flutes	OD [mm]	LOC [mm]	LBS [mm]	SD [mm]	OAL [mm]
5	43332 3016065003	Toric	TS	4	3.0-R0.3	4	16	6	50
6	43332 3016065005	Toric	TS	4	3.0-R0.5	4	16	6	50
7	43332 3017065005	Toric	TS	4	3.0-R0.5	7	17	6	50
8	43332 4012065005	Toric	TS	4	4.0-R0.5	5	12	6	50
9	43332 4012065010	Toric	TS	4	4.0-R1.0	5	12	6	50
10	43332 6020065005	Toric	TS	4	6.0-R0.5	13	20	6	50
11	43332 6020065010	Toric	TS	4	6.0-R1.0	13	20	6	50
12	53332 6013065010	Toric	TS	5	6.0-R1.0	13	-	6	50

## CNC Dental Compatible

### Cobalt Chrome / Titanium

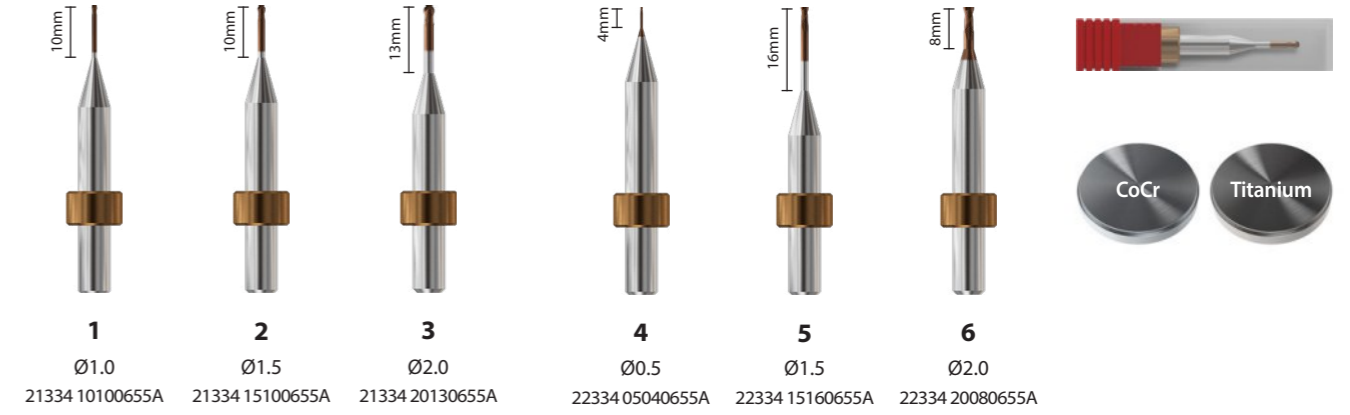

No.	EDP	Type	Coating	Flute	OD [mm]	LOC [mm]	LBS [mm]	SD [mm]	OAL [mm]
1	21334 10100655A	Ball	TS	2	1.0	1	10	6	55
2	21334 15100655A	Ball	TS	2	1.5	1.5	10	6	55
3	21334 20130655A	Ball	TS	2	2.0	2	13	6	55

No.	EDP	Type	Coating	Flute	OD [mm]	LOC [mm]	LBS [mm]	SD [mm]	OAL [mm]
4	22334 05040655A	Flat	TS	2	0.5	1	4	6	55
5	22334 15160655A	Flat	TS	2	1.5	3	16	6	55
6	22334 20080655A	Flat	TS	2	2.0	4	8	6	55

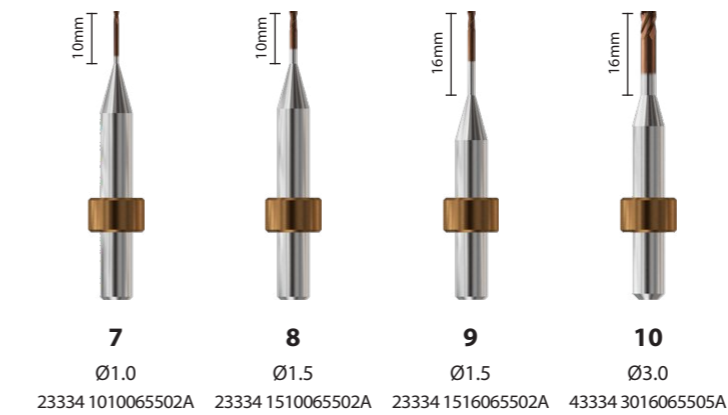

No.	EDP	Type	Coating	Flute	OD [mm]	LOC [mm]	LBS [mm]	SD [mm]	OAL [mm]
7	23334 1010065502A	Toric	TS	2	1.0-R0.2	1.5	10	6	55
8	23334 1510065502A	Toric	TS	2	1.5-R0.2	2.5	10	6	55
9	23334 1516065502A	Toric	TS	2	1.5-R0.2	2.5	16	6	55
10	43334 3016065505A	Toric	TS	4	3.0-R0.5	4	16	6	55

## DATRON Compatible

### Cobalt Chrome / Titanium

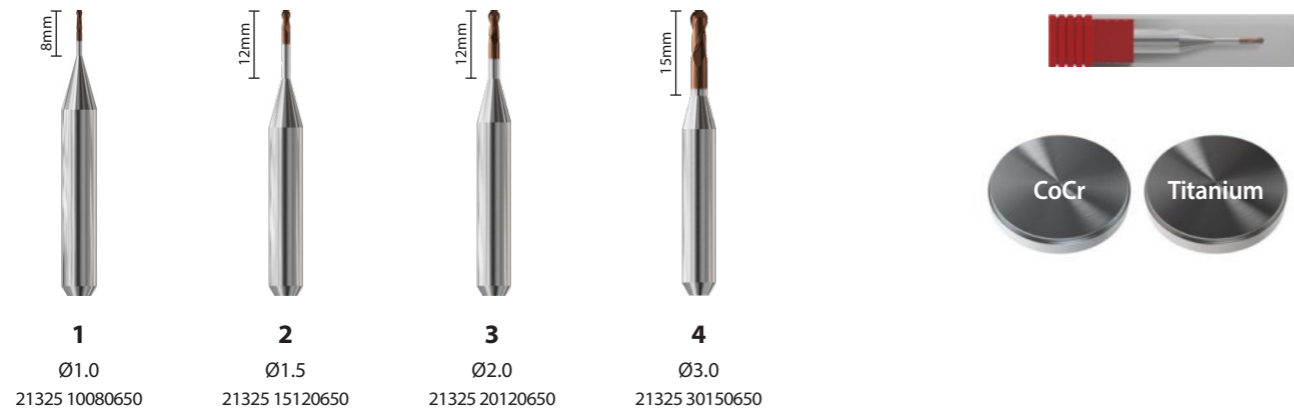

No.	EDP	Type	Coating	Flutes	OD [mm]	LOC [mm]	LBS [mm]	SD [mm]	OAL [mm]
1	21325 10080650	Ball	TS	2	1.0	3	8	6	50
2	21325 15120650	Ball	TS	2	1.5	3	12	6	50
3	21325 20120650	Ball	TS	2	2.0	3.5	12	6	50
4	21325 30150650	Ball	TS	2	3.0	6	15	6	50

## DOF CRAFT-5X

### Zirconia (ZrO<sub>2</sub>)

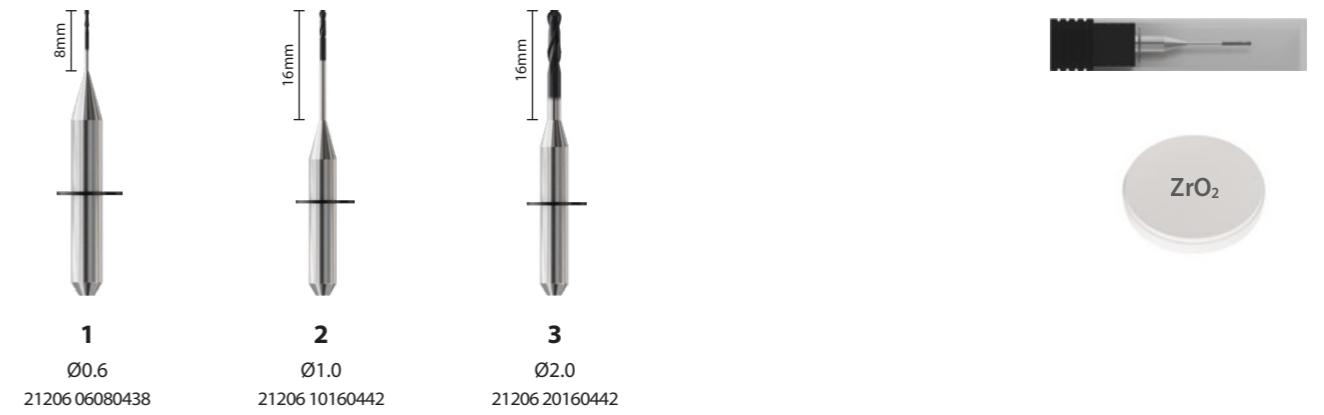

No.	EDP	Type	Coating	Flutes	OD [mm]	LOC [mm]	LBS [mm]	SD [mm]	OAL [mm]
1	21206 06080438	Ball	DIA	2	0.6	2.5	8	4	37.5
2	21206 10160442	Ball	DIA	2	1.0	3.1	16	4	41.5
3	21206 20160442	Ball	DIA	2	2.0	6.3	16	4	41.5

## PMMA



No.	EDP	Type	Coating	Flutes	OD [mm]	LOC [mm]	LBS [mm]	SD [mm]	OAL [mm]
1	21406 10160442	Ball	DLC	2	1.0	3.1	16	4	41.5
2	21406 20160442	Ball	DLC	2	2.0	6.3	16	4	41.5



## DOF CRAFT-5X

### Cobalt Chrome / Titanium

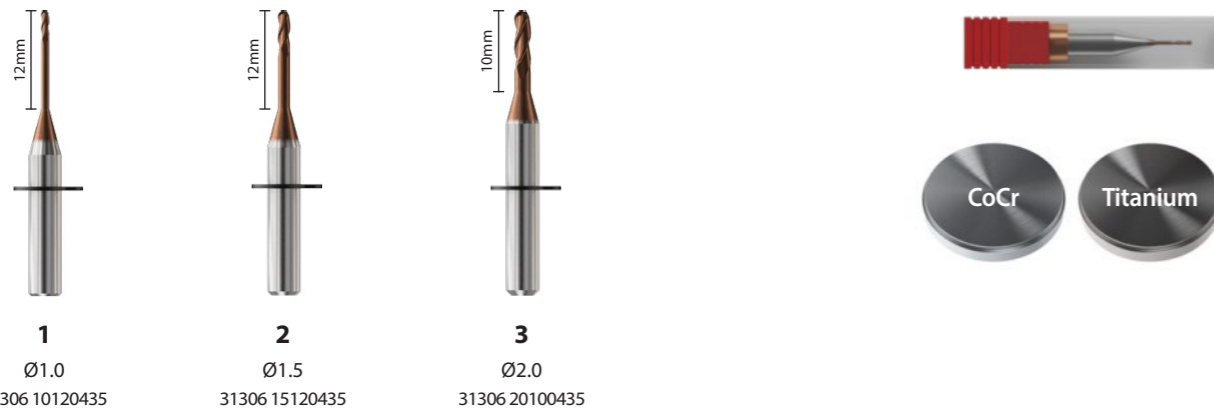

No.	EDP	Type	Coating	Flutes	OD [mm]	LOC [mm]	LBS [mm]	SD [mm]	OAL [mm]
1	31306 10120435	Ball	TS	3	1.0	3	12	4	35
2	31306 15120435	Ball	TS	3	1.5	4	12	4	35
3	31306 20100435	Ball	TS	3	2.0	6	10	4	35

## DOF Sharp2-5X

### Zirconia (ZrO<sub>2</sub>)

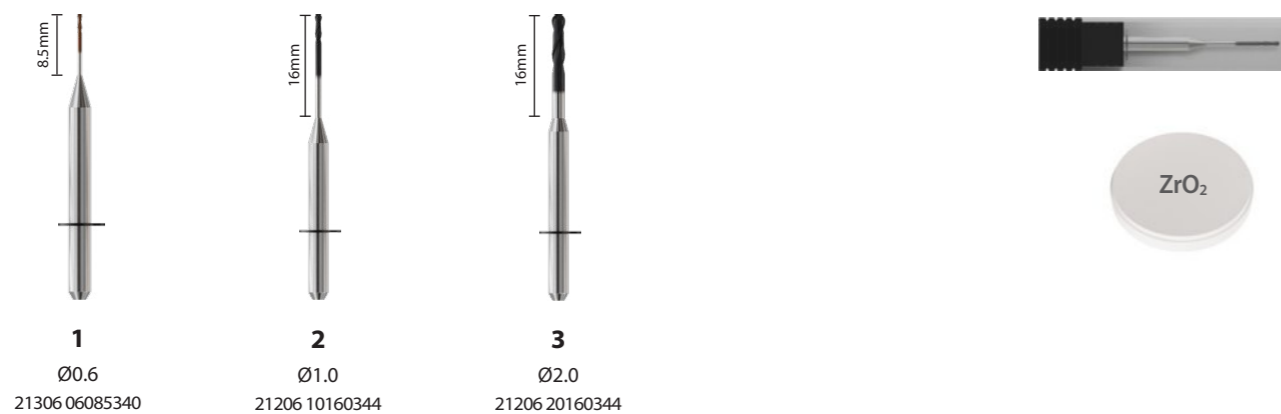

No.	EDP	Type	Coating	Flutes	OD [mm]	LOC [mm]	LBS [mm]	SD [mm]	OAL [mm]
1	21306 06085340	Ball	TS	2	0.6	2	8.5	3	40
2	21206 10160344	Ball	DIA	2	1.0	3.1	16	3	44
3	21206 20160344	Ball	DIA	2	2.0	6.3	16	3	44

## Imes-Icore Compatible Shank 6mm - Dry Machining

### Zirconia (ZrO<sub>2</sub>)

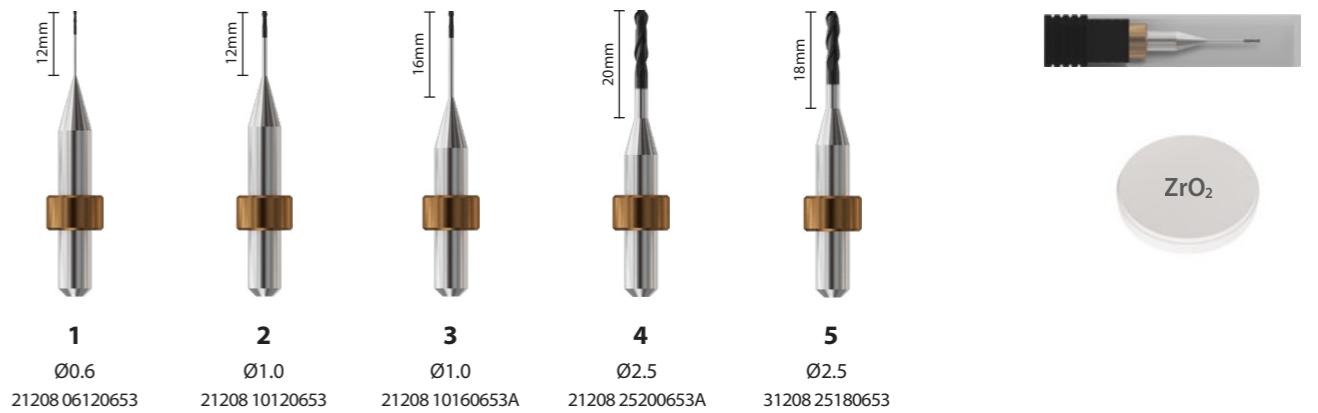

No.	EDP	Type	Coating	Flutes	OD [mm]	LOC [mm]	LBS [mm]	SD [mm]	OAL [mm]
1	21208 06120653	Ball	DIA	2	0.6	2	12	6	53
2	21208 10120653	Ball	DIA	2	1.0	2	12	6	53
3	21208 10160653A	Ball	DIA	2	1.0	2	16	6	53
4	21208 25200653A	Ball	DIA	2	2.5	9	20	6	53
5	31208 25180653	Ball	DIA	3	2.5	9	18	6	53

### PMMA / WAX / PEEK



No.	EDP	Type	Coating	Flutes	OD [mm]	LOC [mm]	LBS [mm]	SD [mm]	OAL [mm]
1	11008 10160648	Ball	Uncoated	1	1.0	6	16	6	48
2	11008 25180648	Ball	Uncoated	1	2.5	6	18	6	48

## Imes-Icore Compatible Shank 6mm

### Cobalt Chrome / Titanium

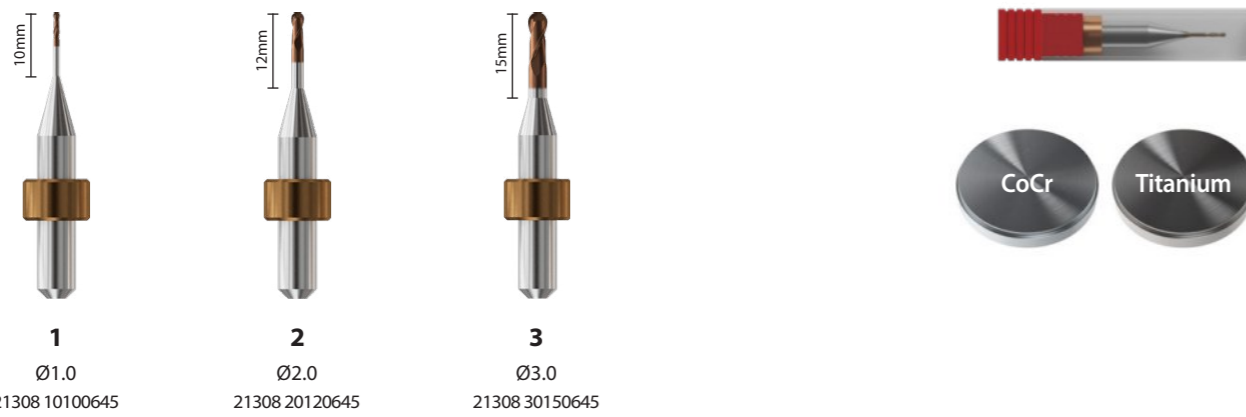

No.	EDP	Type	Coating	Flutes	OD [mm]	LOC [mm]	LBS [mm]	SD [mm]	OAL [mm]
1	21308 10100645	Ball	TS	2	1.0	3	10	6	45
2	21308 20120645	Ball	TS	2	2.0	3.5	12	6	45
3	21308 30150645	Ball	TS	2	3.0	6	15	6	45

## Imes-Icore Compatible Shank 3mm - Dry Machining

### Zirconia (ZrO<sub>2</sub>)



No.	EDP	Type	Coating	Flutes	OD [mm]	LOC [mm]	LBS [mm]	SD [mm]	OAL [mm]
1	21208 06200348	Ball	DIA	2	0.6	4	20	3	48
2	21208 10160348	Ball	DIA	2	1.0	4.4	16	3	48
3	21208 25200348	Ball	DIA	2	2.5	6	20	3	48

## Imes-Icore Compatible - Wet Machining

### Glass Ceramics

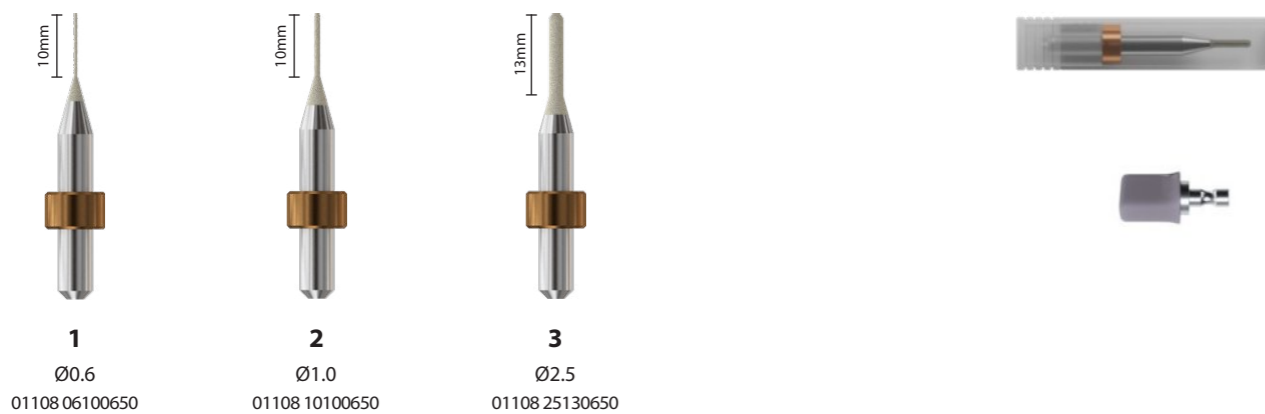

No.	EDP	Type	Coating	Flutes	OD [mm]	LOC [mm]	LBS [mm]	SD [mm]	OAL [mm]
1	01108 06100650	Ball	EL-DIA	N/A	0.6	10	10	6	50
2	01108 10100650	Ball	EL-DIA	N/A	1.0	10	10	6	50
3	01108 25130650	Ball	EL-DIA	N/A	2.5	13	13	6	50

## Imes-Icore Compatible - Wet Machining

### Glass Ceramics



No.	EDP	Type	Coating	Flutes	OD [mm]	LOC [mm]	LBS [mm]	SD [mm]	OAL [mm]
1	01108 06100340	Ball	EL-DIA	N/A	0.6	10	10	3	40
2	01108 10100340	Ball	EL-DIA	N/A	1.0	10	10	3	40
3	01108 25130340	Ball	EL-DIA	N/A	2.5	13	13	3	40

## Redon Compatible - Dry Machining

### Cobalt Chrome / Titanium

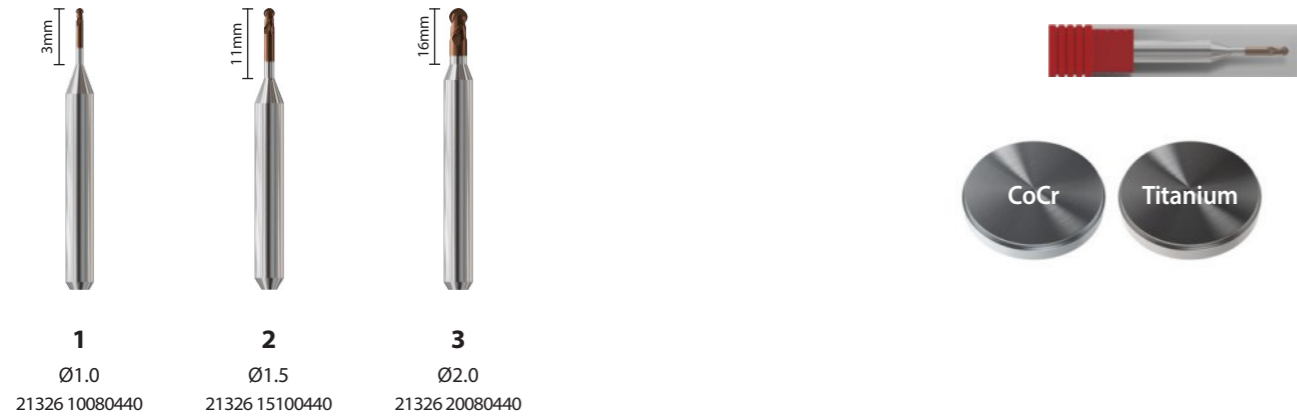

No.	EDP	Type	Coating	Flutes	OD [mm]	LOC [mm]	LBS [mm]	SD [mm]	OAL [mm]
1	21326 10080440	Ball	TS	2	1.0	1.5	8	4	40
2	21326 15100440	Ball	TS	2	1.5	2	10	4	40
3	21326 20080440	Ball	TS	2	2.0	2.5	8	4	40

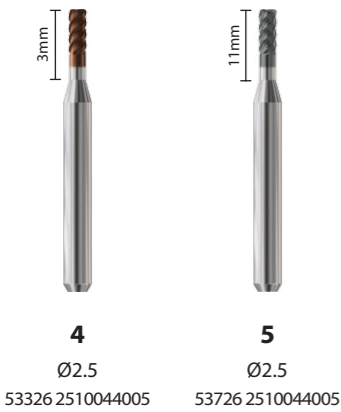

No.	EDP	Type	Coating	Flutes	OD [mm]	LOC [mm]	LBS [mm]	SD [mm]	OAL [mm]
4	53326 2510044005	Toric	TS	5	2.5-R0.5	6	10	4	40
5	53726 2510044005	Toric	AV	5	2.5-R0.5	6	10	4	40

## Redon Compatible - Dry Machining

### Glass Ceramics



No.	EDP	Type	Coating	Flutes	OD [mm]	LOC [mm]	LBS [mm]	SD [mm]	OAL [mm]
1	01126 06060440	Ball	EL-DIA	N/A	0.6	6	6	4	40
2	01126 10100440	Ball	EL-DIA	N/A	1.0	10	10	4	40
3	01126 25150440	Ball	EL-DIA	N/A	2.5	15	15	4	40

## Roland Compatible - Dry Machining

### Zirconia (ZrO<sub>2</sub>)

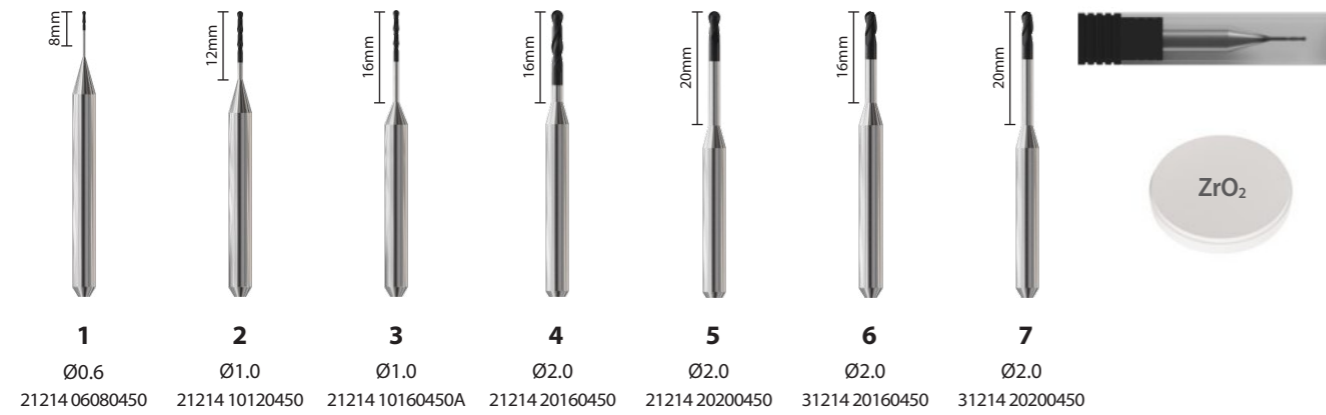

No.	EDP	Type	Coating	Flutes	OD [mm]	LOC [mm]	LBS [mm]	SD [mm]	OAL [mm]
1	21214 06080450	Ball	DIA	2	0.6	2	8	4	50
2	21214 10120450	Ball	DIA	2	1.0	6	12	4	50
3	21214 10160450A	Ball	DIA	2	1.0	6	16	4	50
4	21214 20160450	Ball	DIA	2	2.0	8	16	4	50
5	21214 20200450	Ball	DIA	2	2.0	3	20	4	50
6	31214 20160450	Ball	DIA	3	2.0	4	16	4	50
7	31214 20200450	Ball	DIA	3	2.0	4	20	4	50

### PMMA



No.	EDP	Type	Coating	Flutes	OD [mm]	LOC [mm]	LBS [mm]	SD [mm]	OAL [mm]
1	11514 10120450	Ball	S-DLC	1	1.0	3.3	12	4	50
2	11514 20150450	Ball	S-DLC	1	2.0	11	15	4	50
1*	11014 10120450	Ball	Uncoated (*Option)	1	1.0	3.3	12	4	50
2*	11014 20150450	Ball	Uncoated (*Option)	1	2.0	11	15	4	50

## Roland Compatible - Dry Machining

### Universal Material / WAX / PEEK

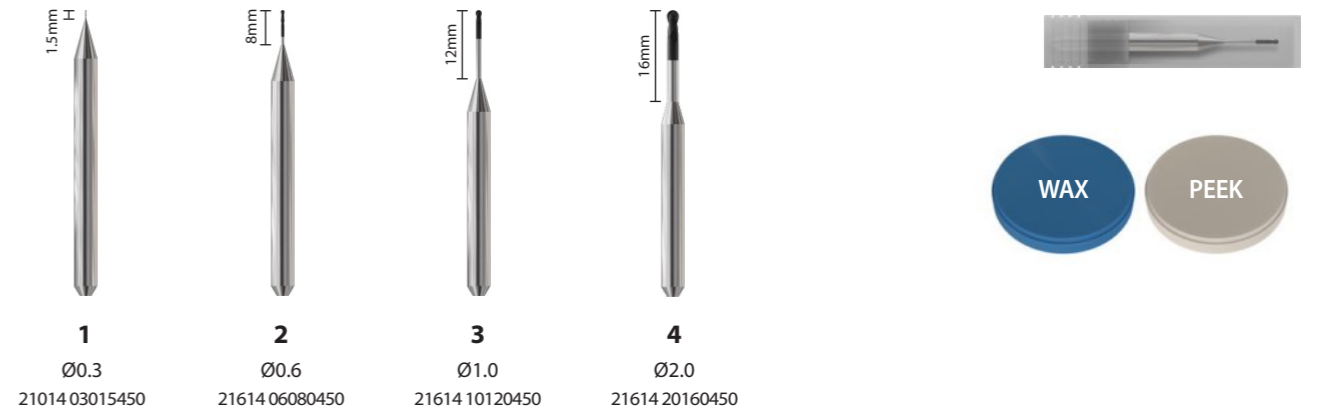

No.	EDP	Type	Coating	Flutes	OD [mm]	LOC [mm]	LBS [mm]	SD [mm]	OAL [mm]
1	21014 03015450	Ball	Uncoated	2	0.3	0.5	1.5	4	50
2	21614 06080450	Ball	TA	2	0.6	0.9	8	4	50
3	21614 10120450	Ball	TA	2	1.0	1.5	12	4	50
4	21614 20160450	Ball	TA	2	2.0	3	16	4	50

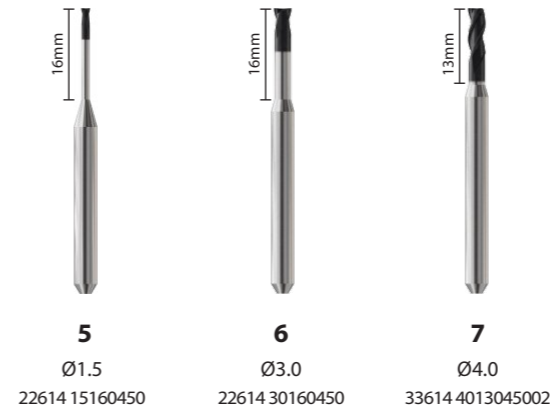

No.	EDP	Type	Coating	Flutes	OD [mm]	LOC [mm]	LBS [mm]	SD [mm]	OAL [mm]
5	22614 15160450	Flat	TA	2	1.5	2.3	16	4	50
6	22614 30160450	Flat	TA	2	3.0	4.5	16	4	50
7	33614 4013045002	Toric	TA	3	4.0-R0.2	13	13	4	50

## Roland Compatible - Wet Machining

### Glass Ceramics

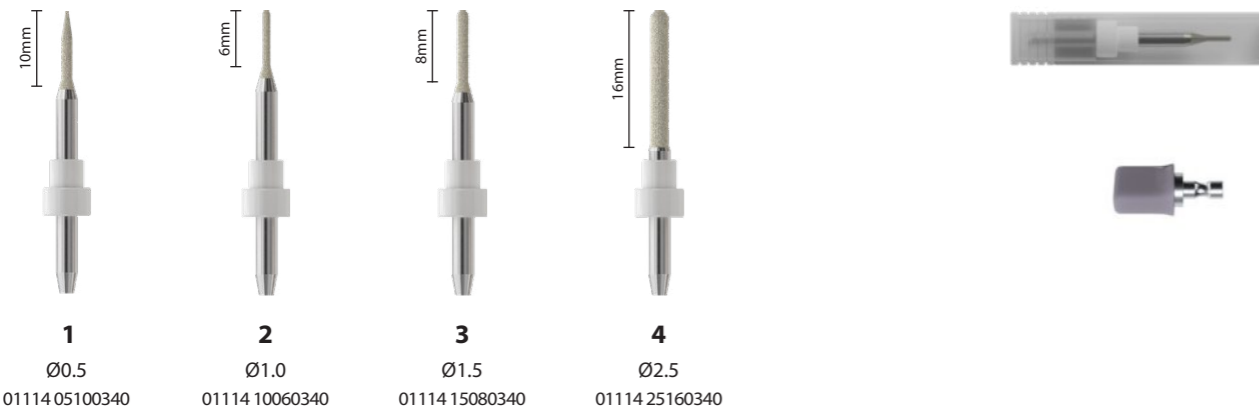

No.	EDP	Type	Coating	Flutes	OD [mm]	LOC [mm]	LBS [mm]	SD [mm]	OAL [mm]
1	01114 05100340	Ball	EL-DIA	N/A	0.5	10	10	3	40
2	01114 10060340	Ball	EL-DIA	N/A	1.0	6	6	3	40
3	01114 15080340	Ball	EL-DIA	N/A	1.5	8	8	3	40
4	01114 25160340	Ball	EL-DIA	N/A	2.5	16	16	3	40

## SIRONA Compatible - Wet Machining

### Zirconia (ZrO<sub>2</sub>)



No.	EDP	Type	Coating	Flutes	OD [mm]	LOC [mm]	LBS [mm]	SD [mm]	OAL [mm]
1	21215 05050342	Ball	DIA	2	0.5	0.6	5	3	42
2	21215 10170343	Ball	DIA	2	1.0	2	17	3	43
3	41215 25240344	Ball	DIA	4	2.5	4	24	3	44

## VHF Compatible - Dry Machining

### Zirconia (ZrO<sub>2</sub>)

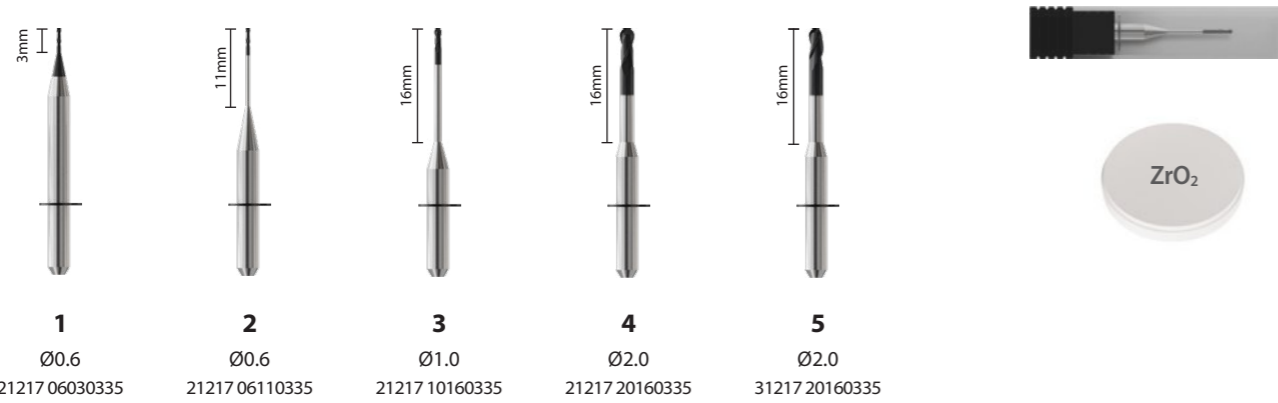

No.	EDP	Type	Coating	Flutes	OD [mm]	LOC [mm]	LBS [mm]	SD [mm]	OAL [mm]
1	21217 06030335	Ball	DIA	2	0.6	1.2	3.0	3	35
2	21217 06110335	Ball	DIA	2	0.6	2	11	3	35
3	21217 10160335	Ball	DIA	2	1.0	2	16	3	35
4	21217 20160335	Ball	DIA	2	2.0	4	16	3	35
5	31217 20160335	Ball	DIA	3	2.0	4	16	3	35

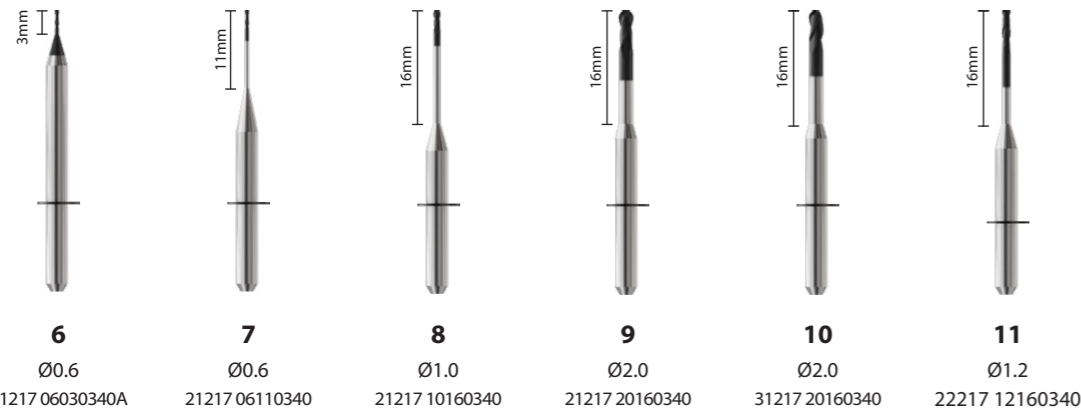

No.	EDP	Type	Coating	Flutes	OD [mm]	LOC [mm]	LBS [mm]	SD [mm]	OAL [mm]
6	21217 06030340A	Ball	DIA	2	0.6	1.2	3.0	3	40
7	21217 06110340	Ball	DIA	2	0.6	2	11	3	40
8	21217 10160340	Ball	DIA	2	1.0	2	16	3	40
9	21217 20160340	Ball	DIA	2	2.0	4	16	3	40
10	31217 20160340	Ball	DIA	3	2.0	4	16	3	40
11	22217 12160340	Flat	DIA	2	1.2	5	16	3	40

## VHF Compatible - Dry Machining

### PMMA / WAX / PEEK

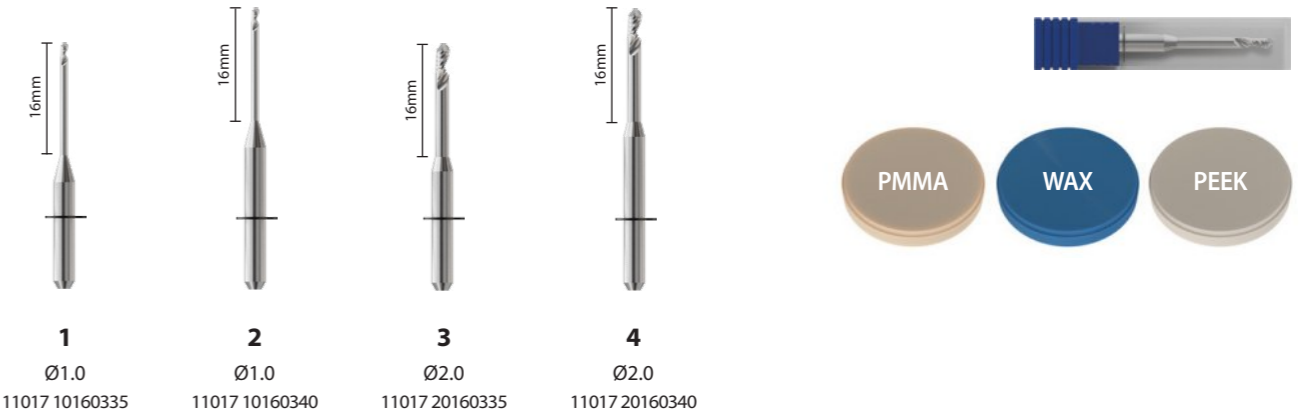

No.	EDP	Type	Coating	Flutes	OD [mm]	LOC [mm]	LBS [mm]	SD [mm]	OAL [mm]
1	11017 10160335	Ball	Uncoated	1	1.0	2	16	3	35
2	11017 10160340	Ball	Uncoated	1	1.0	2	16	3	40
3	11017 20160335	Ball	Uncoated	1	2.0	4	16	3	35
4	11017 20160340	Ball	Uncoated	1	2.0	4	16	3	40

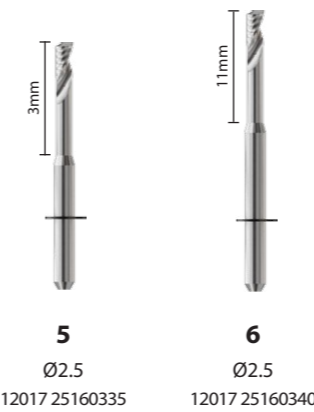

No.	EDP	Type	Coating	Flutes	OD [mm]	LOC [mm]	LBS [mm]	SD [mm]	OAL [mm]
5	12017 25160335	Flat	Uncoated	1	2.5	5	16	3	35
6	12017 25160340	Flat	Uncoated	1	2.5	5	16	3	40

## VHF Compatible - Dry Machining

### Universal Material / WAX / PEEK

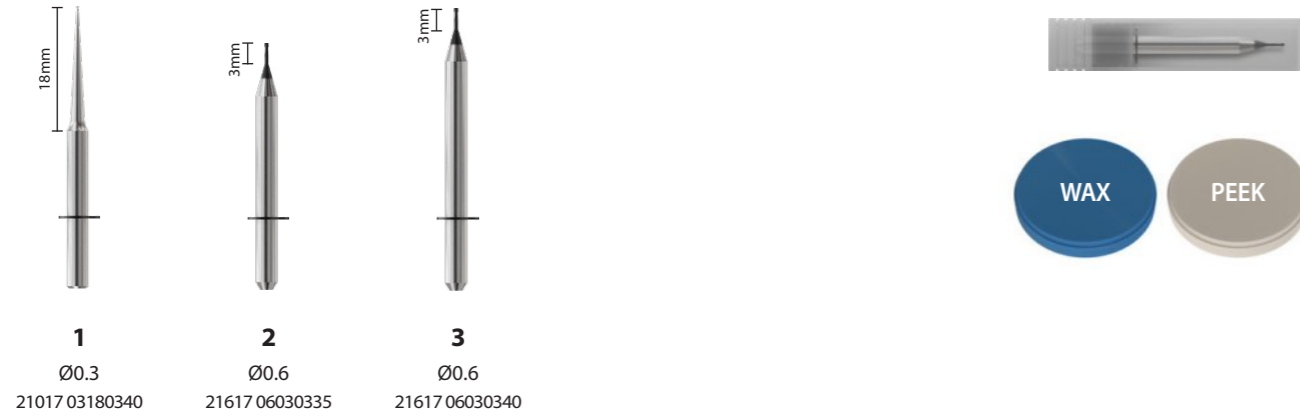

No.	EDP	Type	Coating	Flutes	OD [mm]	LOC [mm]	LBS [mm]	SD [mm]	OAL [mm]
1	21017 03180340	Ball	Uncoated	2	0.3	0.6	18	3	40
2	21617 06030335	Ball	TA	2	0.6	1.2	3	3	35
3	21617 06030340	Ball	TA	2	0.6	1.2	3	3	40

### Glass Ceramics



No.	EDP	Type	Coating	Flutes	OD [mm]	LOC [mm]	LBS [mm]	SD [mm]	OAL [mm]
1	01117 06055335	Ball	EL-DIA	N/A	0.6	5.5	5.5	3	35
2	01117 10080335	Ball	EL-DIA	N/A	1.0	8	8	3	35
3	01117 24160335	Ball	EL-DIA	N/A	2.4	16	16	3	35

## ZIRKONZAHN Compatible - Dry Machining

### Zirconia (ZrO<sub>2</sub>)

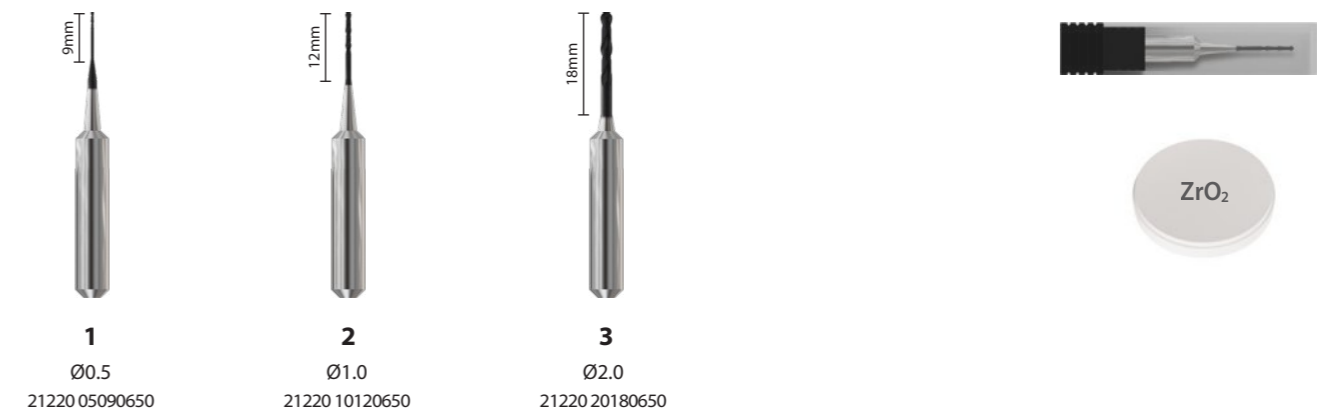

No.	EDP	Type	Coating	Flutes	OD [mm]	LOC [mm]	LBS [mm]	SD [mm]	OAL [mm]
1	21220 05090650	Ball	DIA	2	0.5	3	9	6	50
2	21220 10120650	Ball	DIA	2	1.0	6	12	6	50
3	21220 20180650	Ball	DIA	2	2.0	10	18	6	50

### Zirconia (ZrO<sub>2</sub>)



No.	EDP	Type	Coating	Flutes	OD [mm]	LOC [mm]	LBS [mm]	SD [mm]	OAL [mm]
4	21220 05065357	Ball	DIA	2	0.5	3	6.5	3	57
5	21220 10120357	Ball	DIA	2	1.0	6	12	3	57
6	21220 20180357	Ball	DIA	2	2.0	10	18	3	57

## Technical Questionnaire

\*Company: .....  
 \*Contact: .....  
 \*E-mail: .....  
 Phone: .....

\*Machine Type: ..... CAM System: .....

\*Material:  
 Cobalt Chrome     PMMA / PEEK     Zirconia (ZrO<sub>2</sub>)     Glass Ceramics  
 Titanium     WAX

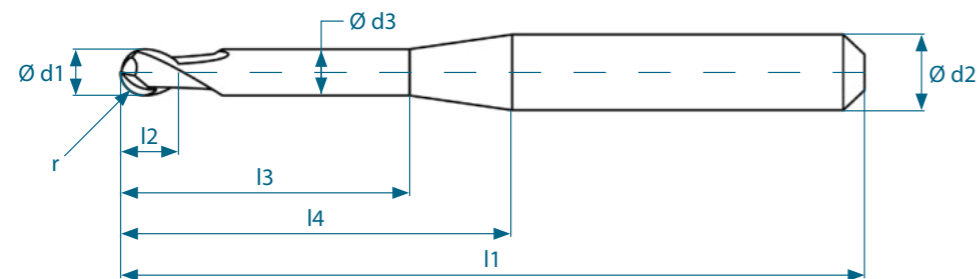



\*Dimensions:  
 Cutting Diameter d1: ..... mm    Overall Length l1: ..... mm  
 Shank Diameter d2: ..... mm    Length of Cut l2: ..... mm  
 Neck Diameter d3: ..... mm    Neck Length l3: ..... mm  
 Radius r: ..... mm    Length of Shank Connection l4: ..... mm

\*Profile:  Ball     Toric     Flat

\*Coating:  Coated     Uncoated    Coating Type: .....

\*Shank Design:

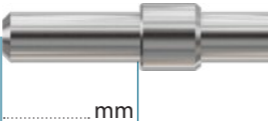
- Cylindrical Shank 
- Cylindrical Shank with Clamping Flat 
- Cylindrical Shank with off-set Neck 
- Cylindrical Shank with Bronze Ring 
- Cylindrical Shank with Synthetic Ring 
- Cylindrical Shank with Snap Ring 
- Cylindrical Shank with Steel Ring 

Notes :  
 \_\_\_\_\_  
 \_\_\_\_\_  
 \_\_\_\_\_  
 \_\_\_\_\_  
 \_\_\_\_\_  
 \_\_\_\_\_  
 \_\_\_\_\_  
 \_\_\_\_\_  
 \_\_\_\_\_  
 \_\_\_\_\_  
 \_\_\_\_\_  
 \_\_\_\_\_  
 \_\_\_\_\_  
 \_\_\_\_\_  
 \_\_\_\_\_  
 \_\_\_\_\_  
 \_\_\_\_\_  
 \_\_\_\_\_