



# Dental

Optimized Tools for CAD-CAM Machines



 **ONEDEN**

# AIDITE AMW-520, AMD-500 Compatible - Dry machining

## Zirconia (ZrO<sub>2</sub>)

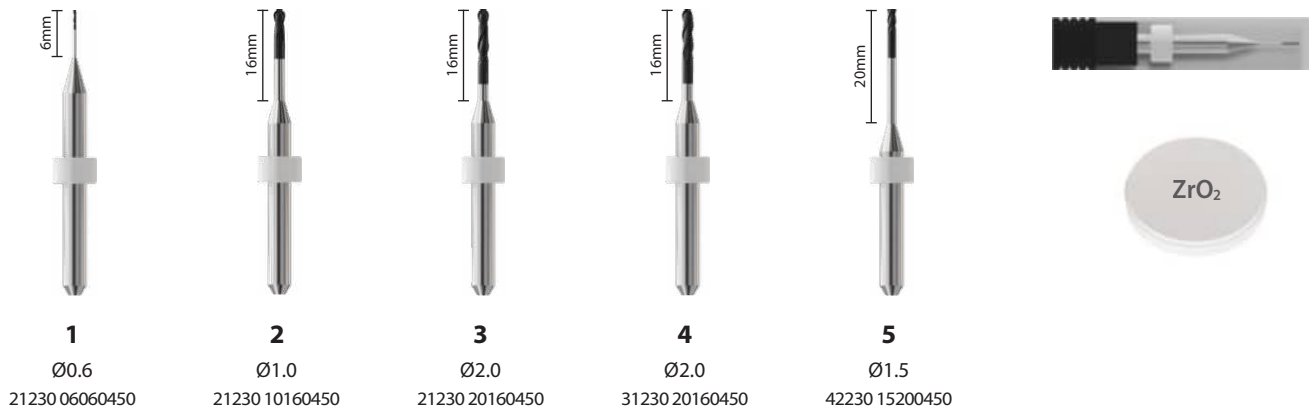

No.	EDP	Type	Coating	Flutes	OD [mm]	LOC [mm]	LBS [mm]	SD [mm]	OAL [mm]
1	21230 06060450	Ball	DIA	2	0.6	1	6	4	50
2	21230 10160450	Ball	DIA	2	1.0	2.5	16	4	50
3	21230 20160450	Ball	DIA	2	2.0	5.5	16	4	50
4	31230 20160450	Ball	DIA	3	2.0	5.5	16	4	50
5	42230 15200450	Flat	DIA	4	1.5	3.5	20	4	50

# AIDITE AMW-520, AMD-500 Compatible - Dry machining

## PMMA

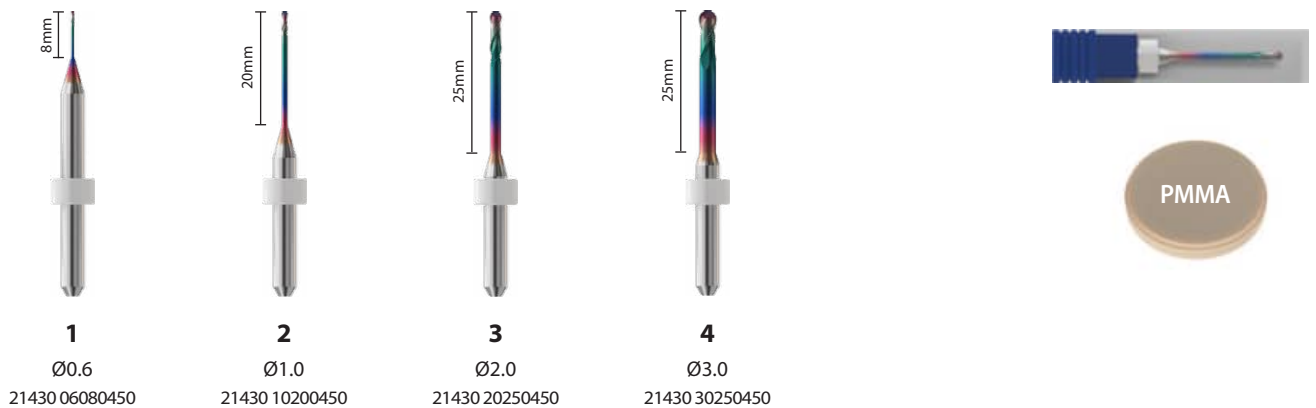

No.	EDP	Type	Coating	Flutes	OD [mm]	LOC [mm]	LBS [mm]	SD [mm]	OAL [mm]
1	21430 06080450	Ball	DLC	2	0.6	2	8	4	50
2	21430 10200450	Ball	DLC	2	1.0	3	20	4	50
3	21430 20250450	Ball	DLC	2	2.0	8	25	4	50
4	21430 30250450	Ball	DLC	2	3.0	8	25	4	50

## AIDITE AMW-520, AMD-500 Compatible - Dry machining

### PMMA

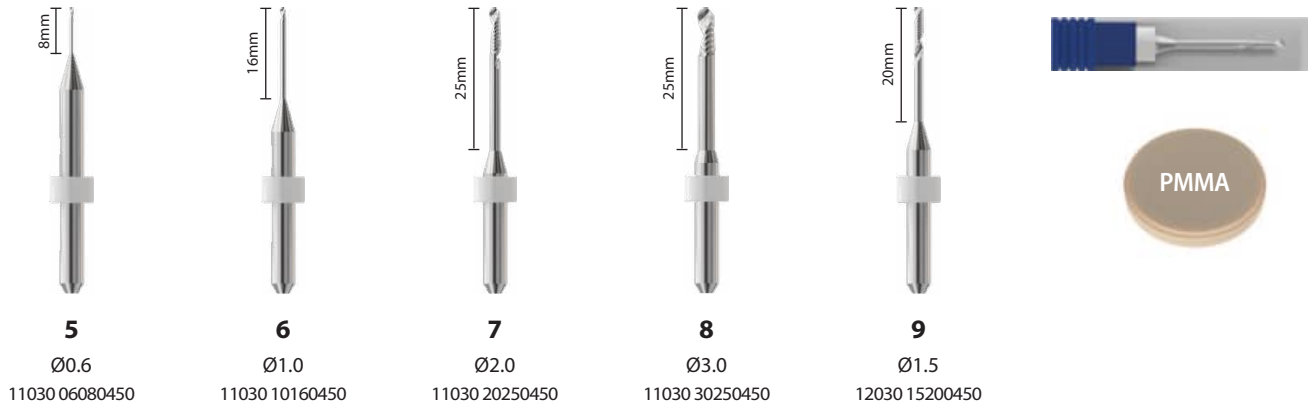

No.	EDP	Type	Coating	Flutes	OD [mm]	LOC [mm]	LBS [mm]	SD [mm]	OAL [mm]
5	11030 06080450	Ball	Uncoated	1	0.6	2	8	4	50
6	11030 10160450	Ball	Uncoated	1	1.0	2	16	4	50
7	11030 20250450	Ball	Uncoated	1	2.0	8	25	4	50
8	11030 30250450	Ball	Uncoated	1	3.0	8	25	4	50
9	12030 15200450	Flat	Uncoated	1	1.5	8	20	4	50

## AIDITE AMW-00 Compatible - Wet Machining

### lass Ceramics

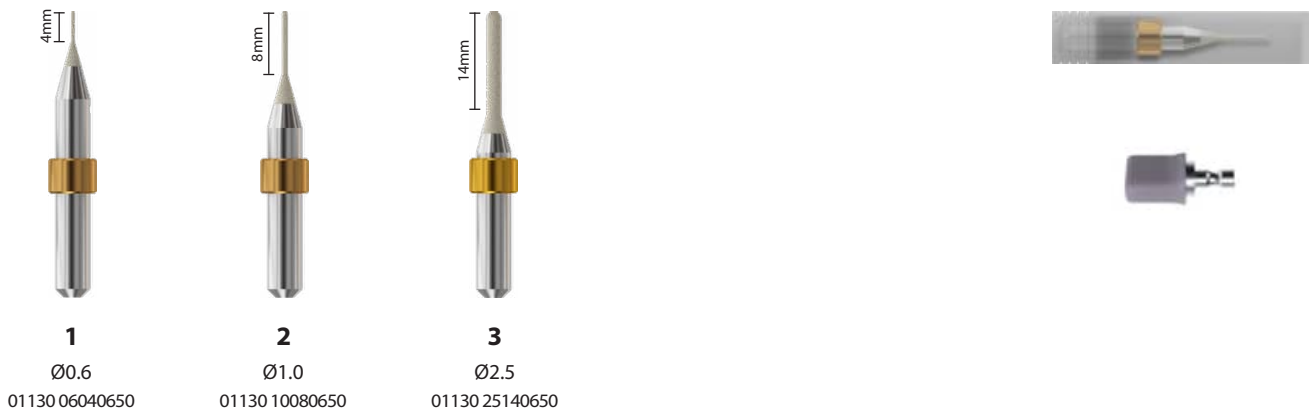

No.	EDP	Type	Coating	Flutes	OD [mm]	LOC [mm]	LBS [mm]	SD [mm]	OAL [mm]
1	01130 06040650	Ball	EL-DIA	0	0.6	4	4	6	50
2	01130 10080650	Ball	EL-DIA	0	1.0	8	8	6	50
3	01130 25140650	Ball	EL-DIA	0	2.5	14	14	6	50



47-2 Cheongnong-ro Bupueong-gu, Incheon, South Korea

✉ oneden@oneden.kr

☎ +82 32 513 2344

☎ +82 32 724 4340

<https://www.oneden.kr>

