



Dental

Optimized Tools for CAD-CAM Machines



 **ONEDEN**

Imes-Core Compatible Shank 6mm - Dry Machining

Zirconia (ZrO₂)

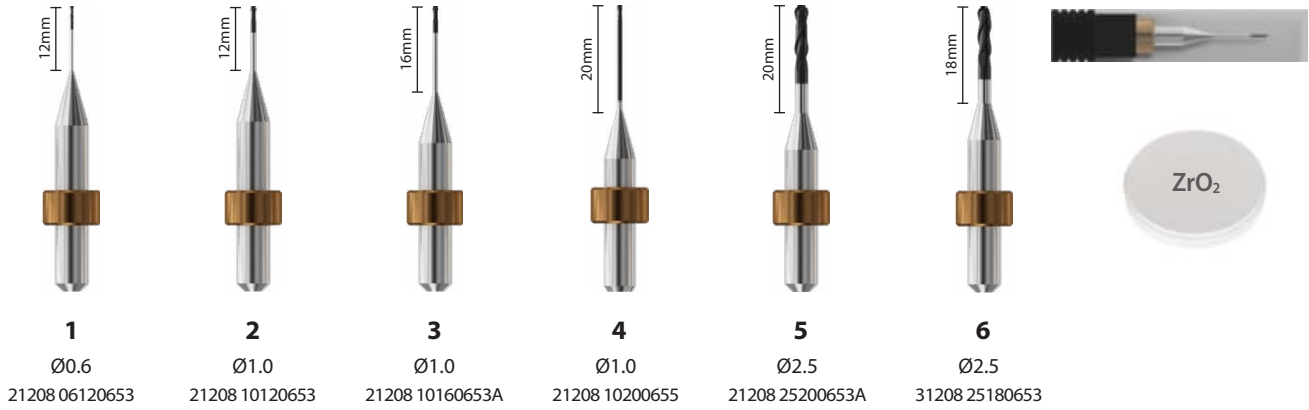

No.	EDP	Type	Coating	Flutes	OD [mm]	LOC [mm]	LBS [mm]	SD [mm]	OAL [mm]
1	21208 06120653	Ball	DIA	2	0.6	2	12	6	53
2	21208 10120653	Ball	DIA	2	1.0	2	12	6	53
3	21208 10160653A	Ball	DIA	2	1.0	2	16	6	53
4	21208 10200655	Ball	DIA	2	1.0	2	20	6	55
5	21208 25200653A	Ball	DIA	2	2.5	9	20	6	53
6	31208 25180653	Ball	DIA	3	2.5	9	18	6	53

PMMA / WAX / PEEK

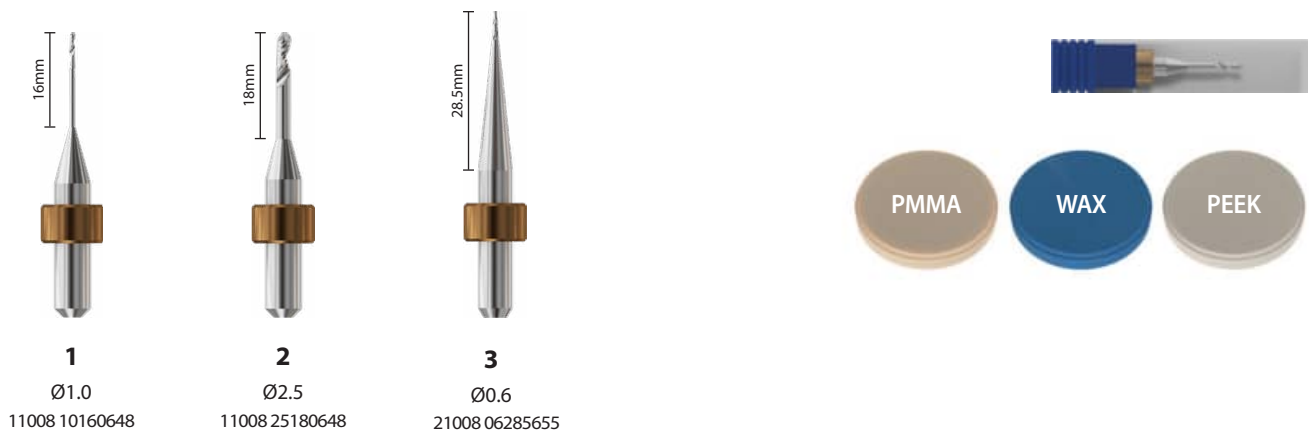

No.	EDP	Type	Coating	Flutes	OD [mm]	LOC [mm]	LBS [mm]	SD [mm]	OAL [mm]
1	11008 10160648	Ball	Uncoated	1	1.0	6	16	6	48
2	11008 25180648	Ball	Uncoated	1	2.5	6	18	6	48
3	21008 06285655	Ball	Uncoated	2	0.6	4	28.5	6	55

Imes-Core Compatible Shank 6mm

Cobalt Chrome / Titanium

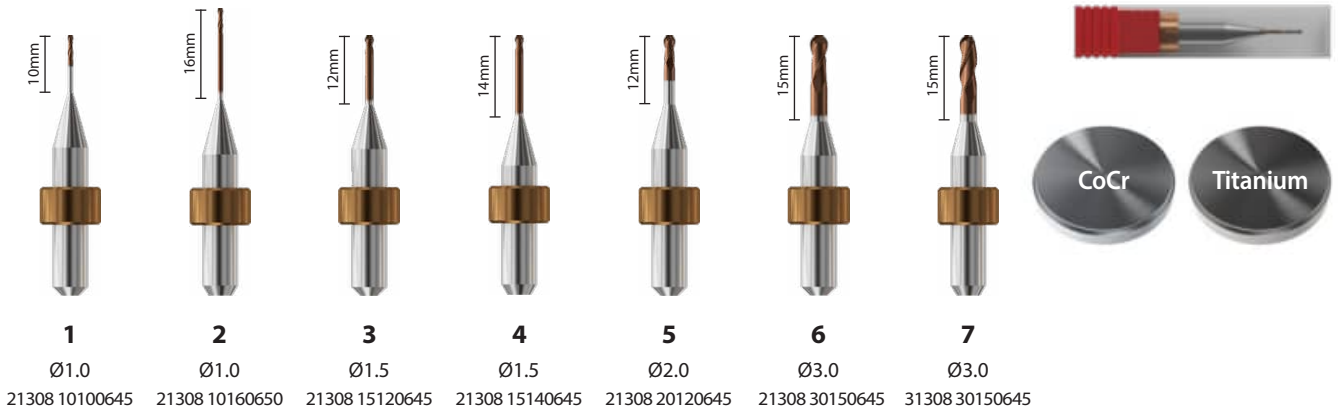

No.	EDP	Type	Coating	Flutes	OD [mm]	LOC [mm]	LBS [mm]	SD [mm]	OAL [mm]
1	21308 10100645	Ball	TS	2	1.0	3	10	6	45
2	21308 10160650	Ball	TS	2	1.0	1.2	16	6	50
3	21308 15120645	Ball	TS	2	1.5	1.25	12	6	45
4	21308 15140645	Ball	TS	2	1.5	1.25	14	6	45
5	21308 20120645	Ball	TS	2	2.0	3.5	12	6	45
6	21308 30150645	Ball	TS	2	3.0	6	15	6	45
7	31308 30150645	Ball	TS	3	3.0	8	15	6	45

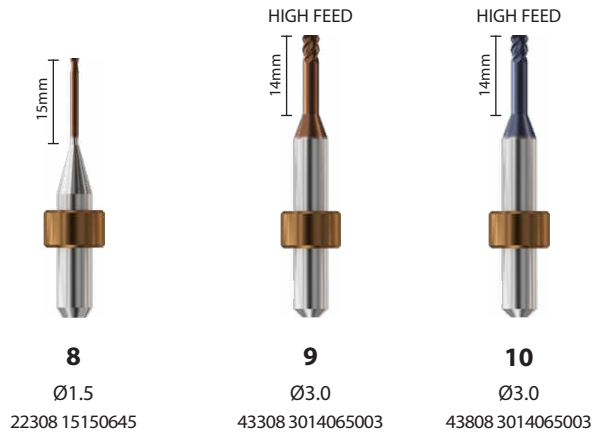

No.	EDP	Type	Coating	Flutes	OD [mm]	LOC [mm]	LBS [mm]	SD [mm]	OAL [mm]
8	22308 15150645	Flat	TS	2	1.5	2.5	15	6	45
9	43308 3014065003	High Feed	TS	4	3.0 -R0.3	4	14	6	50
10	43808 3014065003	High Feed	AT	4	3.0 -R0.3	4	14	6	50

Imes-Icore Compatible Shank 6mm - Wet Machining

Glass Ceramics

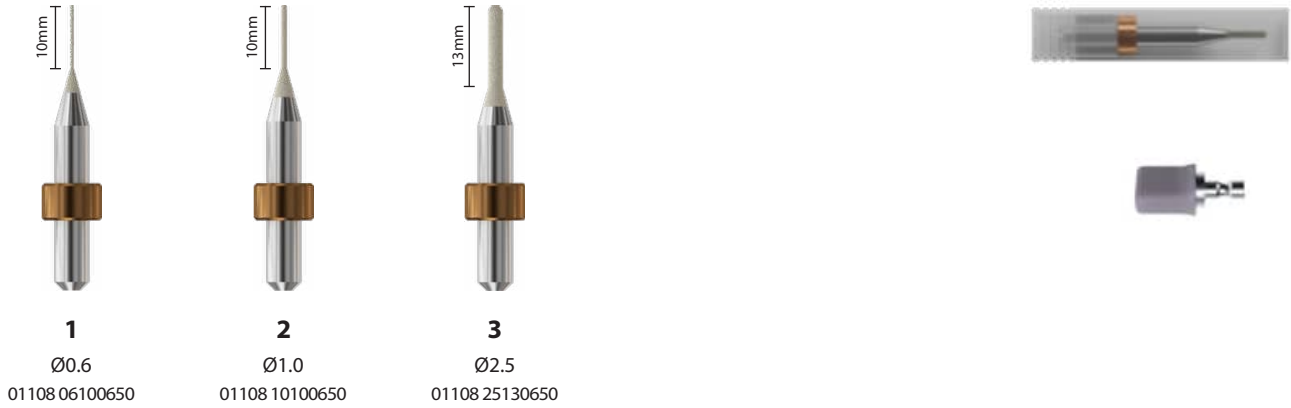

No.	EDP	Type	Coating	Flutes	OD [mm]	LOC [mm]	LBS [mm]	SD [mm]	OAL [mm]
1	01108 06100650	Ball	EL-DIA	0	0.6	10	10	6	50
2	01108 10100650	Ball	EL-DIA	0	1.0	10	10	6	50
3	01108 25130650	Ball	EL-DIA	0	2.5	13	13	6	50

Imes-Core Compatible Shank 3mm - Dry Machining

Zirconia (ZrO₂)

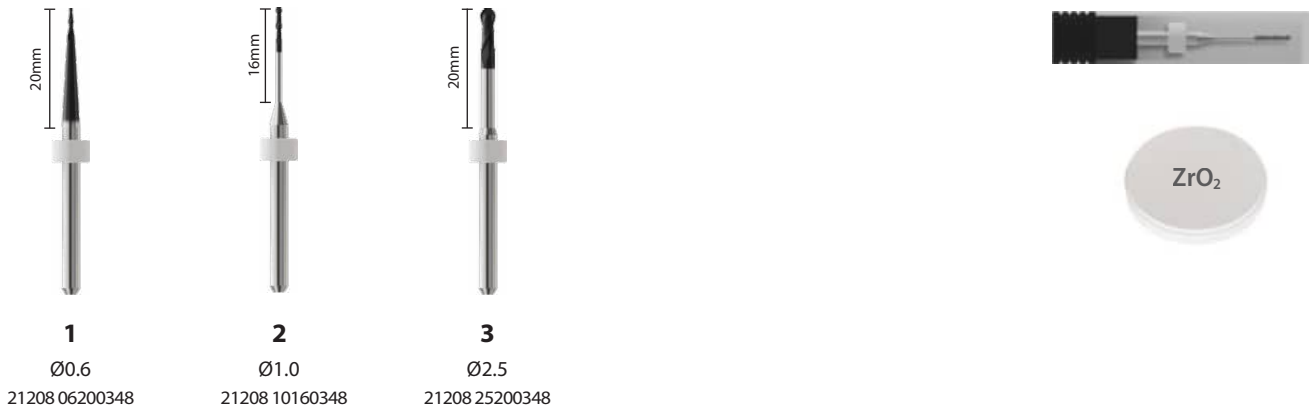

No.	EDP	Type	Coating	Flutes	OD [mm]	LOC [mm]	LBS [mm]	SD [mm]	OAL [mm]
1	21208 06200348	Ball	DIA	2	0.6	4	20	3	48
2	21208 10160348	Ball	DIA	2	1.0	4.4	16	3	48
3	21208 25200348	Ball	DIA	2	2.5	6	20	3	48

Imes-Core Compatible - Wet Machining

Glass Ceramics

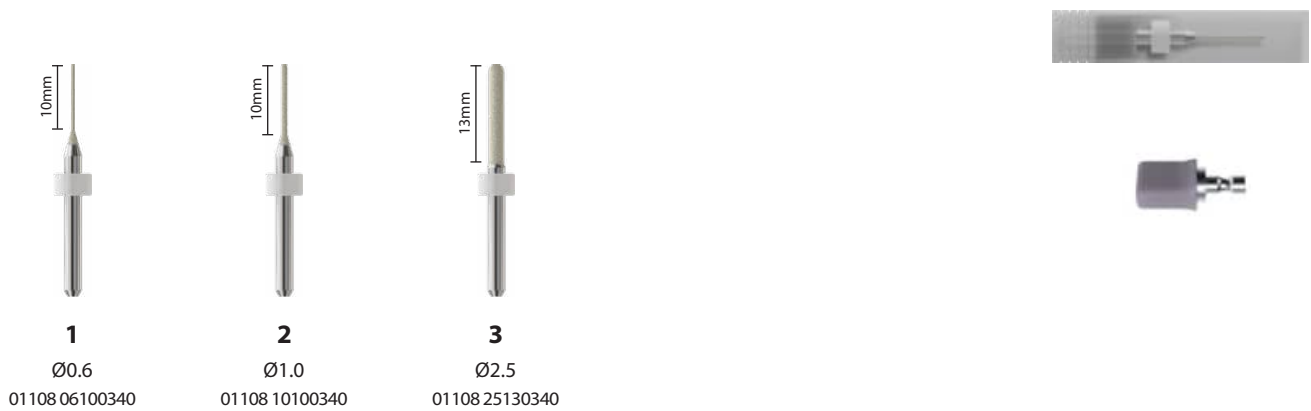

No.	EDP	Type	Coating	Flutes	OD [mm]	LOC [mm]	LBS [mm]	SD [mm]	OAL [mm]
1	01108 06100340	Ball	EL-DIA	0	0.6	10	10	3	40
2	01108 10100340	Ball	EL-DIA	0	1.0	10	10	3	40
3	01108 25130340	Ball	EL-DIA	0	2.5	13	13	3	40



47-2 Cheongnong-ro Bupueong-gu, Incheon, South Korea

✉ oneden@oneden.kr

☎ +82 32 513 2344

☎ +82 32 724 4340

<https://www.oneden.kr>

